

SIMPLE & RADICAL

A DIY noise circuit by Max Wainwright.
Radical Chip by John Richards and Max Wainwright

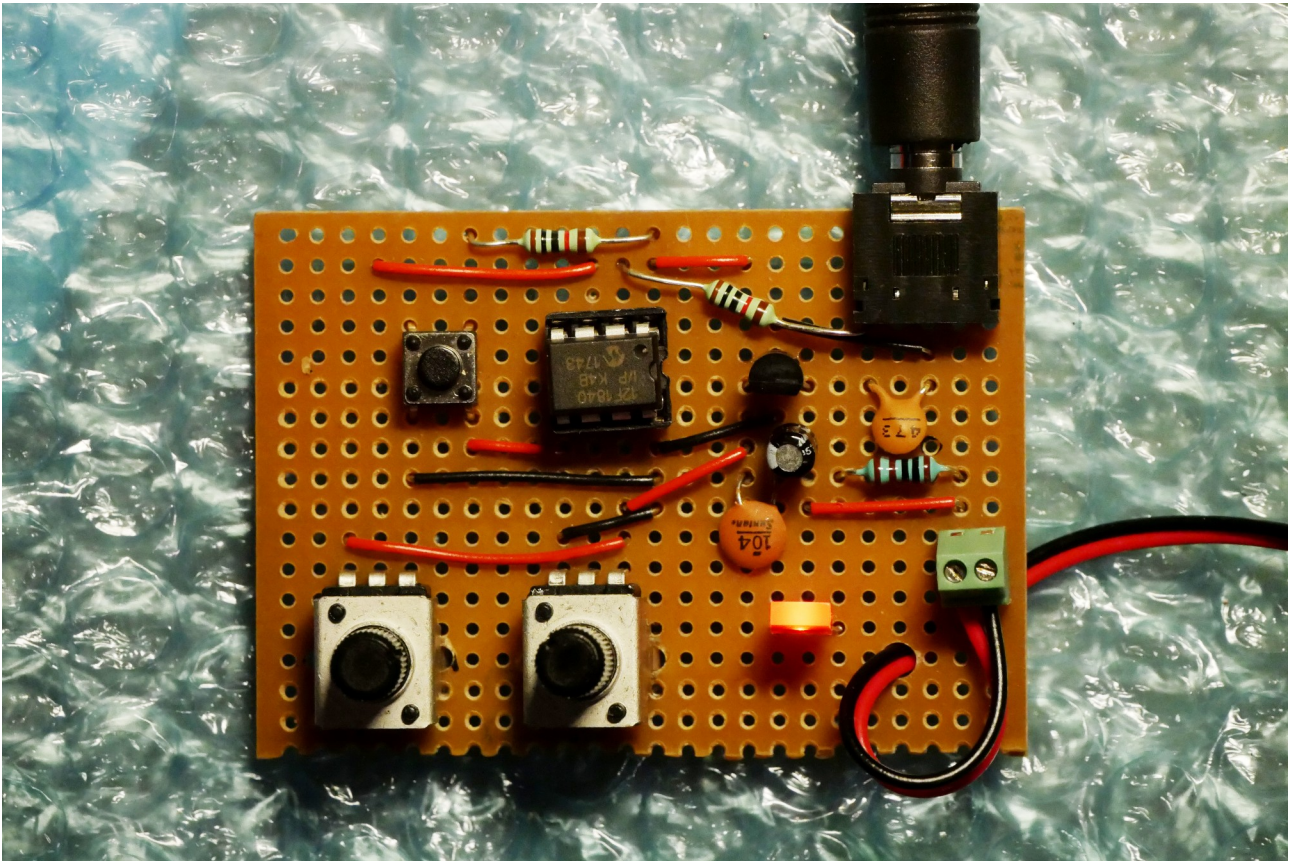

To build the Simple & Radical (snr) you will need these parts:

(Many parts can be omitted or swapped, especially if you know what you are doing, but these are the ones used in the pictures and will work. All parts are through-hole. Links to shops and more below.)

- **The Radical Chip.**
- **A piece of stripboard** (sometimes called veroboard. The one I use is 24*17 holes.)
- **A DIL-8 socket.**
- **Two potentiometers** (I suggest Bourns PTV09 series, 10K linear (B), they're the nicest 9mm pcb mount pots I have used, and cheap. Or try ALPS RK09 series or Alpha RV09, or any other pot that fits in a stripboard (2.54mm spacing). There is a cheap blue kind of trimmer with a knob, they fit too. Other values such as 100K, 50K, 500K etc are ok, and logarithmic pots should also work fine).
- **A momentary button** (6 × 6mm kind. It needs to be normally open).
- **Two 10k resistors** (I use metal film resistors. Metal film colour bands: brown black black red brown).
- **One 1k resistor** (colour bands: brown black black brown brown)

- **An LED** (Shows that the circuit is powered. Red is nice).
- **One 1nF capacitor** (Sometimes called 0.001 uF. Ceramic is fine, or polyester. 5mm pitch (leg spacing) is best. Not an electrolytic capacitor).
- **One 100nF capacitor** (Sometimes called 0.1uF. Ceramic ... etc as above).
- **One electrolytic capacitor** in the 10-100uF range (voltage something above 10V, I suggest 16V/25V for smaller size).
- **One 78L05 voltage regulator.**
- **A stereo audio jack** (the sound is mono, but the stereo function is used as a power switch, so only mono cables will work. More on this below).
- **A battery clip** for a 9V (PP3) battery.
- **A 2.54mm screw terminal** (Optional. Not shown in this instruction, goes in the power connection holes if you decide to use one – see top photo).
- **Some wire** (A few colours can be nice to keep them apart).

And these tools:

A soldering iron (25W pen is fine, don't need fancy stuff).

Solder (lead free).

Something to clean the soldering iron with (sponge/scouring pad).

Side cutters.

Wire strippers.

Blu-tack or masking tape (to fix components to the board before soldering).

A 2mm drill bit (preferably, 3mm can work).

A 3mm drill bit (for metal).

A drill to drive the bits.

A Stanley/snap-off blade knife/box cutter (whatever you call them, the cheap kind, not a woodworking knife).

A small screwdriver (if you decide to use the screw terminal).

A simple multimeter (if and when you screw things up).

Read all of these instructions before beginning.

First, use the knife to score the stripboard to an appropriate size, then snap it over the edge of a table. When this is done, you can begin placing a few parts so you can orientate yourself.

Double-check the positioning (counting holes from the edges) before you solder. It does help when following these instructions if you have the same board size as I do. Parts can be moved around as long as the same connections are made (refer the schematic if you want to do this).

I tend to start with the IC socket. Having done this, cut the tracks at the places marked with an X using the 3mm drill bit. Make sure that the copper is completely cut, but don't go through the board. If you are using 9mm snap-in potentiometers, you can drill the holes for these now using a 2mm drill bit (drill from the copper side). Also drill the strain relief hole (3mm drill bit).

Double check before drilling!

When cutting tracks and drilling, remember to follow the right picture. Everything is flipped on the back :-)

After this, solder in place the things that are easy to fit and which help with orienting other things. A suggested order: the jack, the button, the voltage regulator, the resistors, the

ceramic capacitors, the electrolytic capacitor, the LED, the wires, the screw terminal, the potentiometers. Double-check placement before soldering. If you are new at soldering, check out this tutorial: <https://learn.sparkfun.com/tutorials/how-to-solder-through-hole-soldering>

Note: the following parts have a polarity and can only go in one way. Otherwise they will break/not work/break other things.

- **The electrolytic capacitor.** The minus side is labeled on the body with a – sign and the plus side has a longer leg.
- **The LED.** The plus side has a longer leg.
- **The 78L05 voltage regulator.** It has a rounded side and a flat side: look at the drawing to see which way it goes.
- It is also possible to put the button in the wrong way, if you try hard.
- (The potentiometers *can* go in backwards, but will work either way. There is no “up” in the Radical Chip.)

When everything is soldered in place, screw the battery leads into the terminal (make sure to put + (red) and - (black) in the correct connectors). After this you need to insert the Radical Chip. It is very important to have the notch in the chip facing towards the jack (see the drawing).

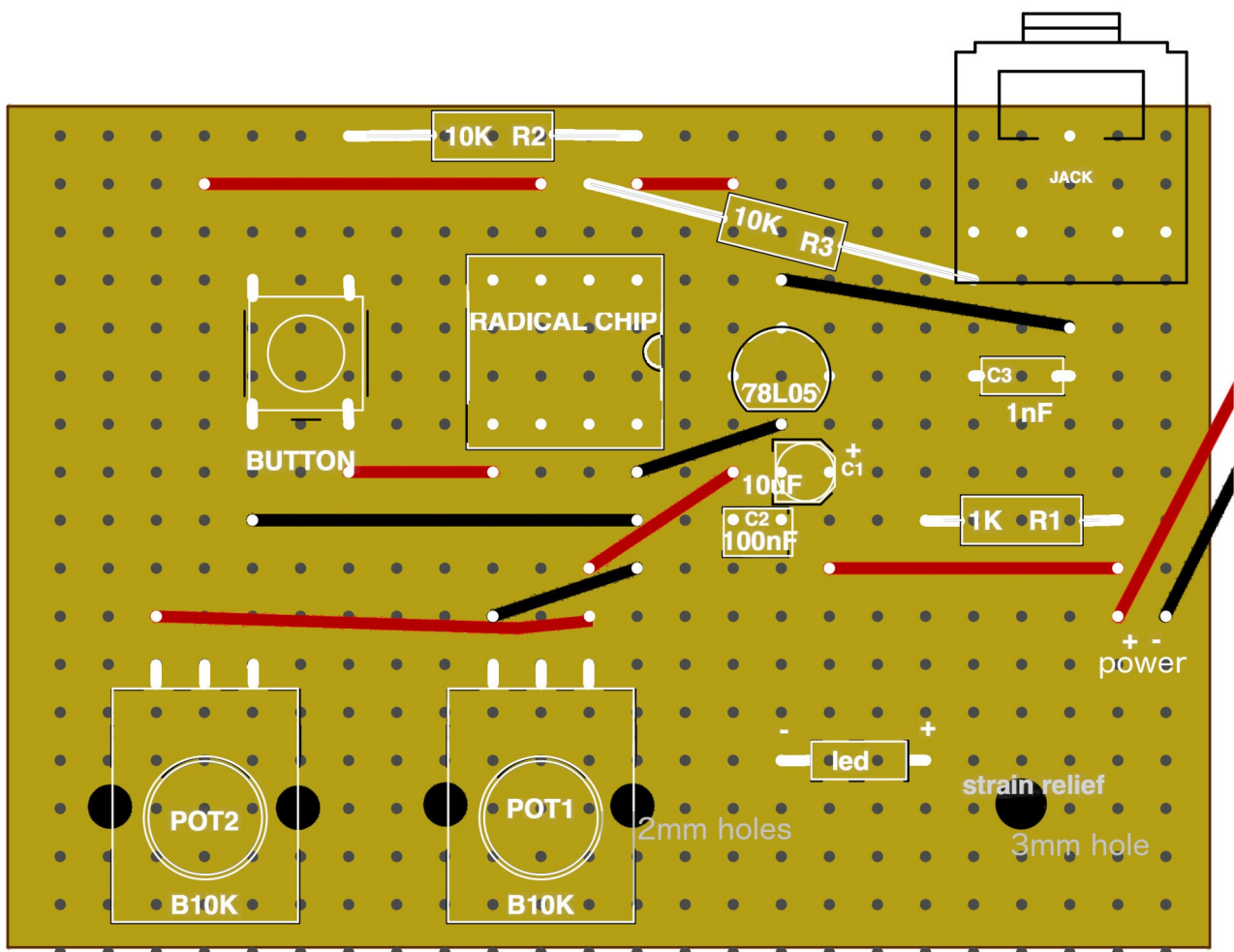

Top view. Black spots are drill holes (make sure to drill from the bottom side)

Done!

If the snr doesn't make a sound when you first turn it on, unplug the battery or jack quickly and begin checking for errors. If you did something wrong, things may start smoking if you leave the power connected. Some things that can go wrong:

- **Part in wrong place** (follow tracks, make sure it shares the track with same parts as in the drawing).
- **Part in wrong orientation** (applies to 78L05 voltage regulator, electrolytic capacitor, LED, Radical Chip, power wires)
- **Insufficiently cut tracks.**
- **Short-circuits** (solder bridging between tracks).
- **Wrong kind of part** (wrong value resistor or capacitor, different jack etc).

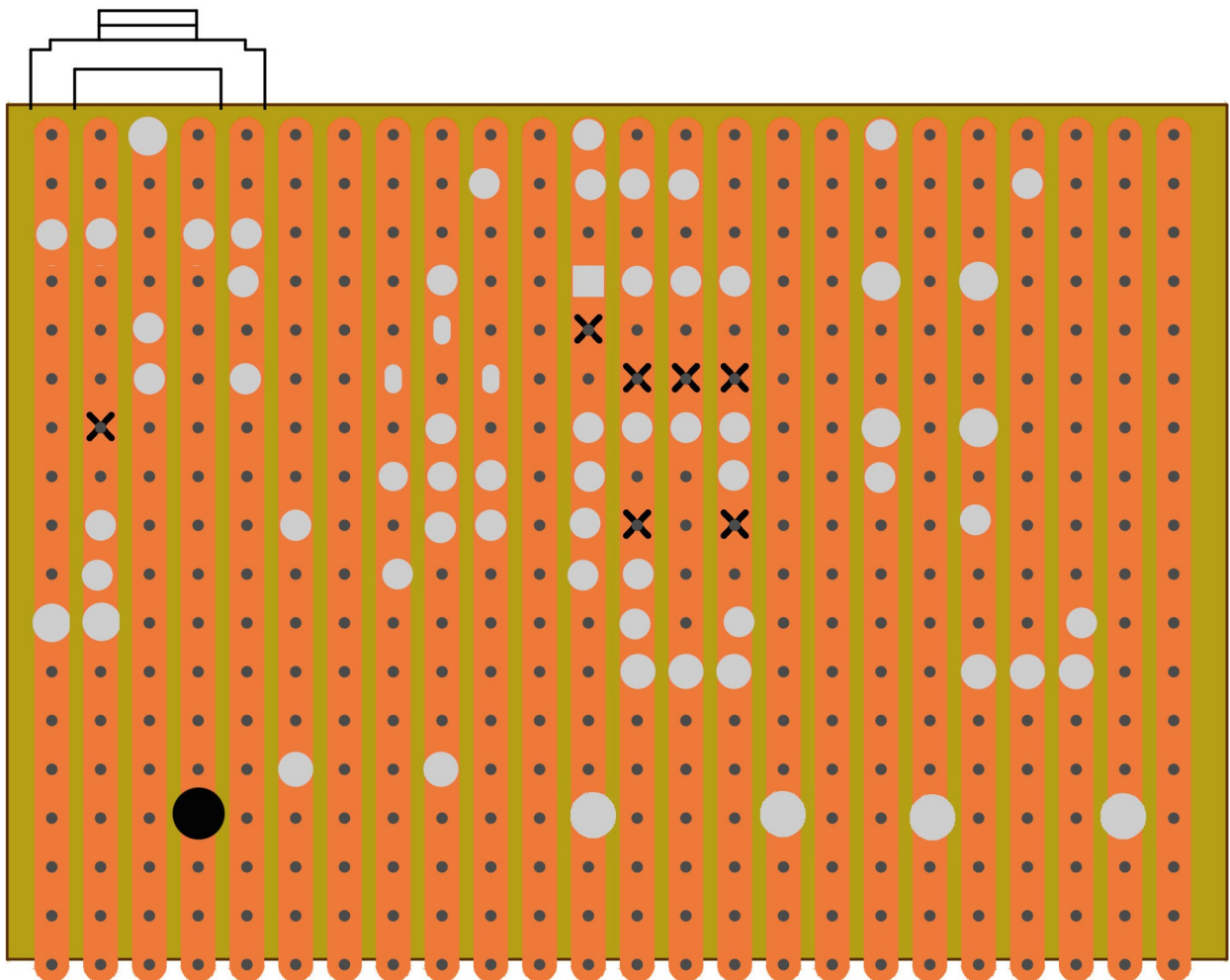

Bottom view. X-es are cuts, grey spots are solder points.

About the circuit:

The Radical Chip needs power, inputs, an output and a button to function. This circuit uses two potentiometers as voltage dividers to create the inputs: voltages from 0-5V. Other options are using analog sensors (air pressure, light, etc), sound (which needs to be amplified a bit), control voltages from an analog synthesizer (these need to be constrained to 0-5V), or touch (using 5V, ground and the two inputs as touch pins).

The button changes which program runs. The mode pin on the chip (pin 5) is tied to 5V via a 10K resistor, and a momentary button (normally open) pulls the input low, i.e. connects it to ground, when pressed. The button could be replaced with a transistor or other electronic switch of some kind to automate the pressing of the button. The result is still random.

The output of the Radical Chip is a digital PWM signal: varying pulse-widths of a high-frequency pulse-train. To get analog values, a low pass (RC) filter is used to filter out the pulse frequency, leaving low values when the pulse width is low, and high when it is high. This filter is a very simple and cheap DAC, and it works great. ~~The 47nF capacitor gives a good sound, a 100nF would also work if that's what you have but the sound will be duller. Use a 1nF capacitor!~~ Or 2.2/4.7nF, or something similarly low. Much better

There's no op amp or any buffering on in the circuit, we just take the output straight from the microchip. The only "protection" from what it is plugged into is the resistor in the DAC. I think the chip will drive most stuff just ok, but if you're plugging it into strange equipment, maybe run it through a mixer or a guitar pedal (overdrive or booster) first. The world needs more distortion.

For power, the chip wants 2.3-5.5V. The absolute maximum is 6.5V, but this is not comfortable for the chip. When making this layout, I first put the voltage regulator in backwards, feeding around 8V into the chip. It survived, but don't do it. In this circuit I use a 78L05 voltage regulator, which takes 9V from a square battery and produces 5V (plus some heat).

Another option I've tried is using four AA or AAA batteries, which give 6V, and connect the power through a diode, for instance a 1n4148 or 1n4001, which drops the voltage by around 1V. Diodes are really cheap and the batteries should last a bit longer that way. It also protects the circuit from connecting the battery the wrong way. The circuit should run fine on two or three AA/AAA batteries too, which would give it 3 or 4.5V.

There is no power switch in this circuit, instead the battery is connected so that power is only supplied when a plug (*mono* plug) is plugged into the jack. It will *not* work with a stereo plug.

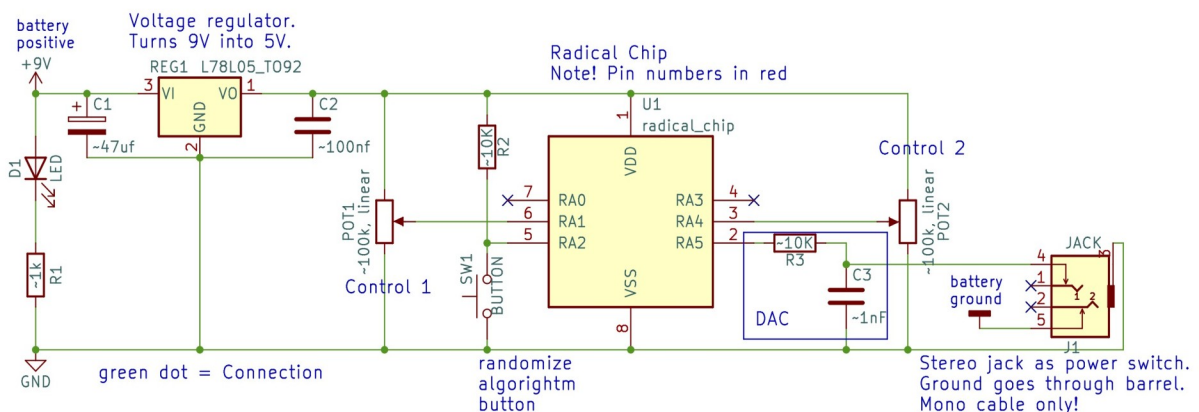

Some shops that should sell the needed parts or equivalents:

www.sparkfun.com

www.electrokit.com

www.rapidonline.com

www.hobbytronics.co.uk/

<http://www.tronixlabs.com.au/>

Please avoid places like banggood, aliexpress, ebay, amazon etc. It's really not worth it. Support hobbyist-oriented electronics suppliers. (disclaimer: I work at Electrokit)
RS, Digi-key, Mouser, Farnell and other industrial suppliers are ok too, but their websites take some getting used to.

Good luck!

Max Wainwright

March 2019

Updated March 2024

contact: info@noise.technology

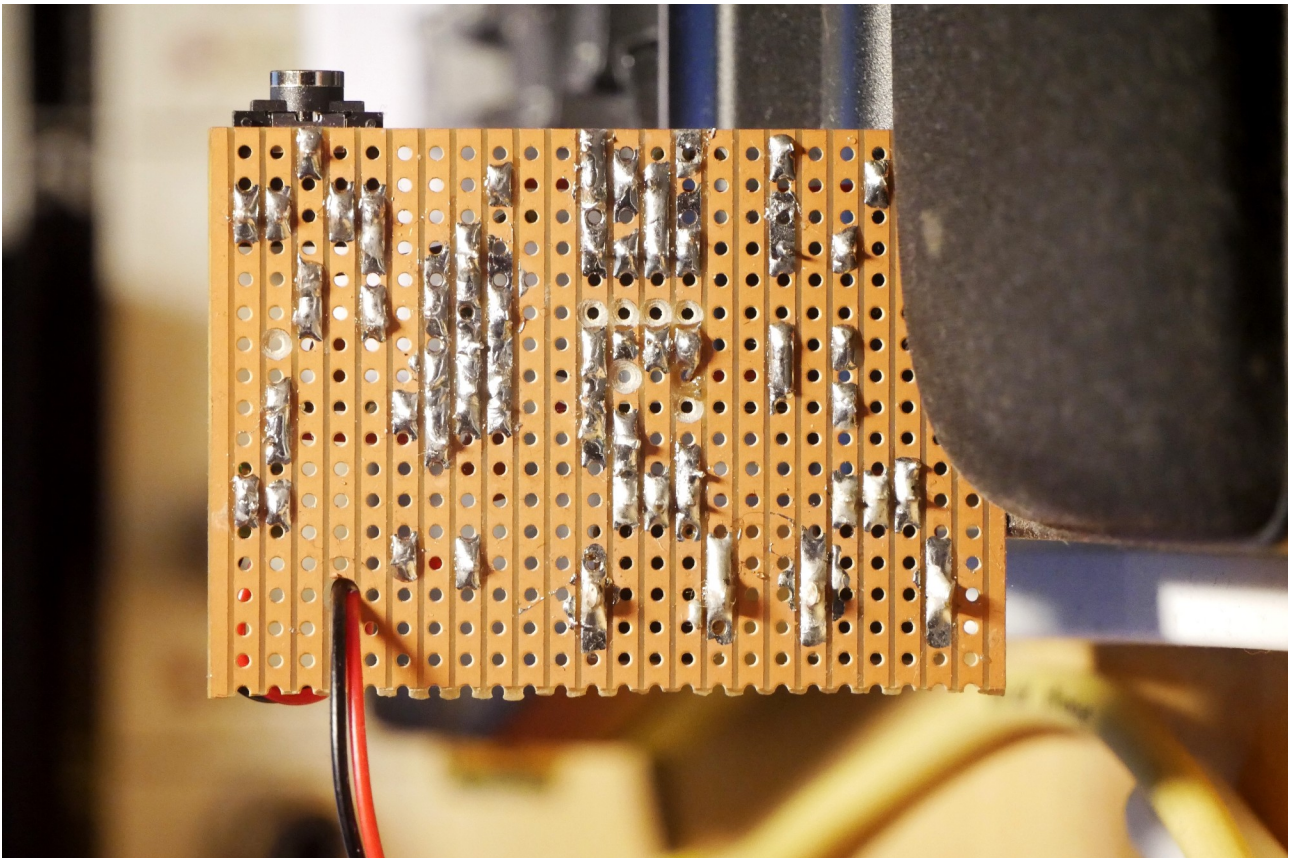

Back of the stripboard.